

**Toll Free  
(844)-  
448-3207**

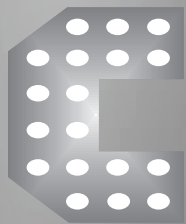

**WWW.  
SupplyBright  
.Net**



***FastClip*** <sup>TM</sup>

**NO-WELD SYSTEM**

*Standard Awning Designs Showcasing  
FastClip location, Type and Use*

**Z-CLIP**

*Standard Awning Designs Showcasing  
Z-Clip Technical Information*

**125 Corporation Way, Suite F, Venice Florida 34285  
V - 941-460-1600 f - 844-780-0910  
www.SupplyBright.Net Sales@SupplyBright.Net**

**MATCHED  
STAPLE SYSTEM  
COMPONENT**

**COMPLETE ASSEMBLY WITHOUT WELDING  
FIX BROKEN WELDS IN THE FIELD.  
15 Piece Minimum Order - Mix 'N Match**

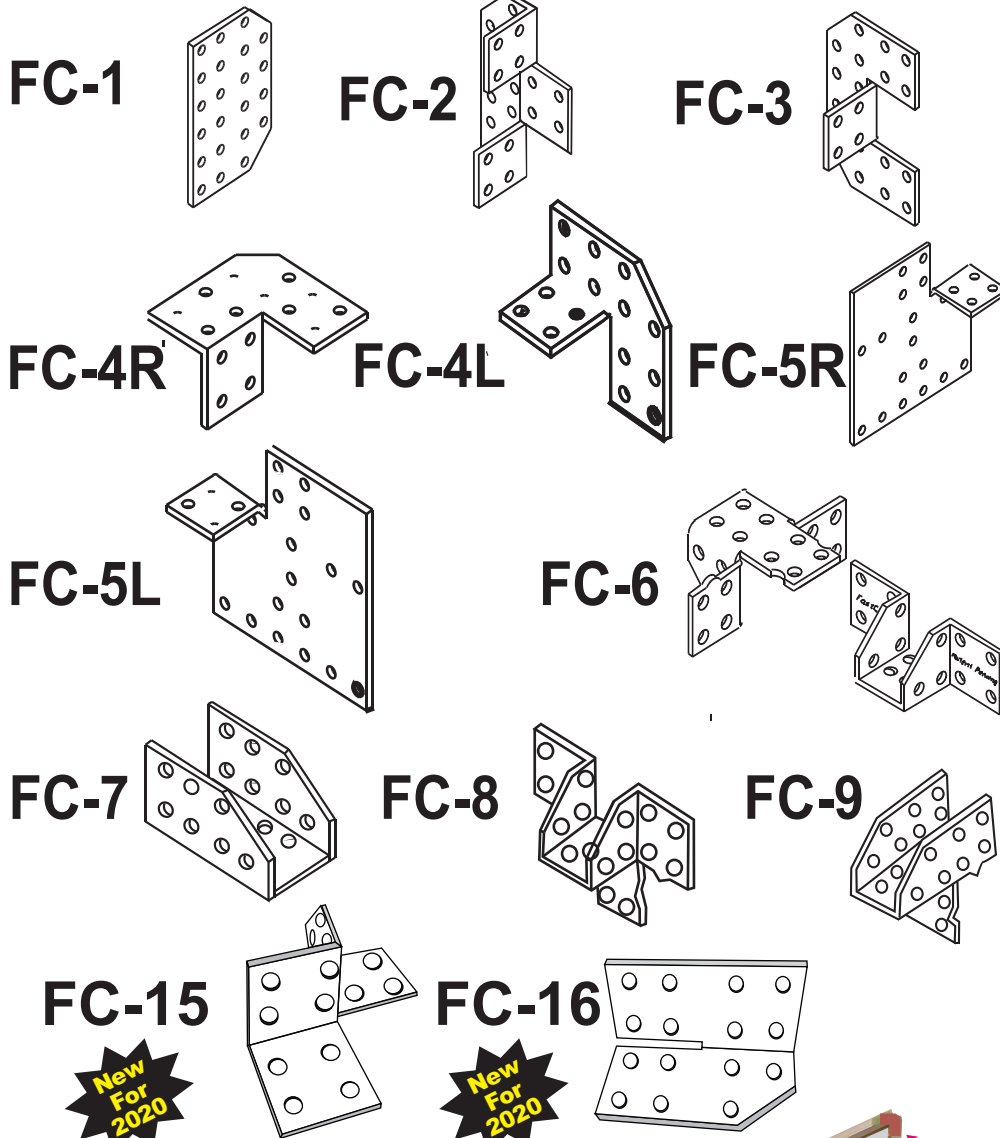
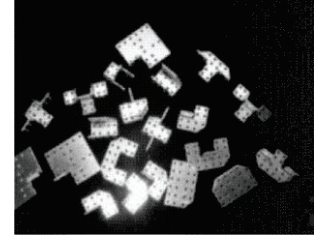

FastClip System completely eliminates the need for welding awning or sign components together.

Now you do not need to buy or maintain costly welding equipment or have trained welders on staff.

All you need is a screw gun and self tapping tek screws. When used with the patented Milliken Profile (aluminum extrusion) and our proven staple system, the FastClip System is a good solution for anyone who wants to produce great products quickly and profitably!

The FastClip System is comprised of 9 different designs, and used in combination can assemble any size and shape sign or awning.

The FastClip System is designed to work effectively and give a tight bond only when used with the Milliken Original extrusions. The Milliken Original extrusions have their own special outer contours upon which the FastClips are designed. This includes the Milliken Profiles and the square tubing shapes offered by Supply Bright, which work together and is yet another part of the Milliken Matched Component System.

**Traditional Style Truss  
Assembled with No Weld**

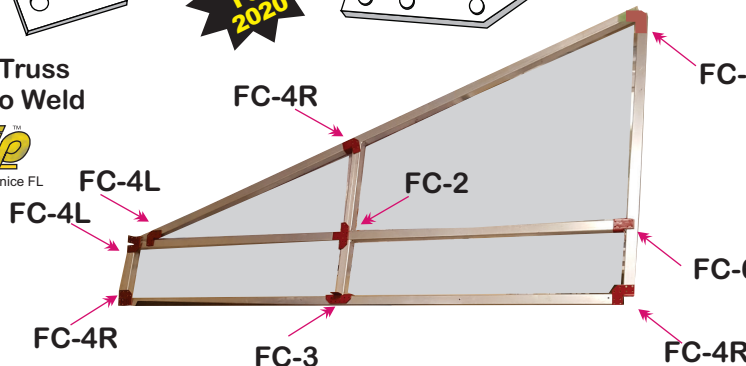



# INSTALLATION INSTRUCTIONS

Fasten clips to awning structure using tek-screws and screw gun as shown in the illustration that most closely resembles the awning you are fabricating

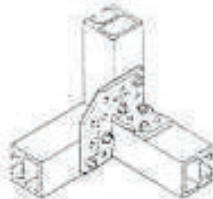
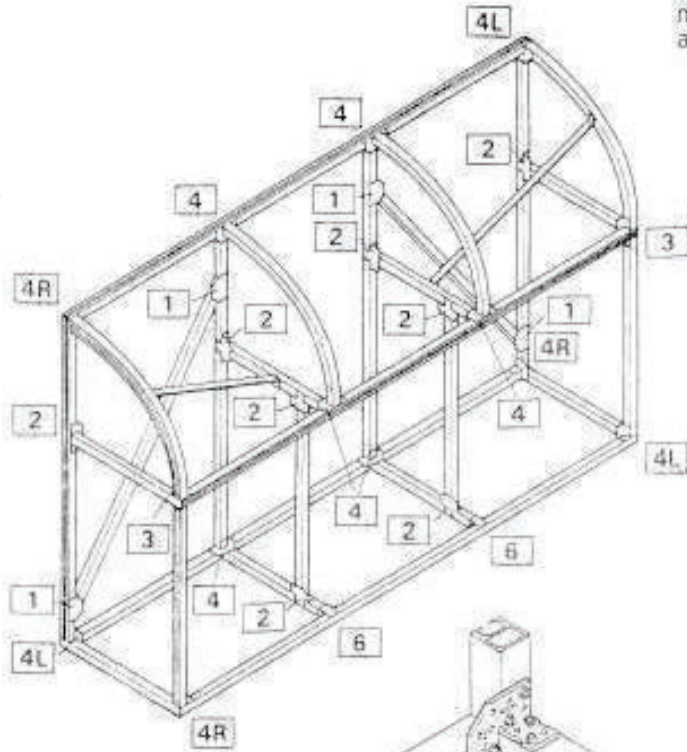

SAMPLE INSTALLATION SHOWING HOW CLIP 4L IS ATTACHED TO FRAME

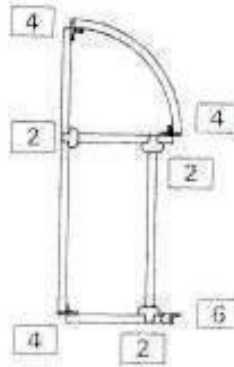
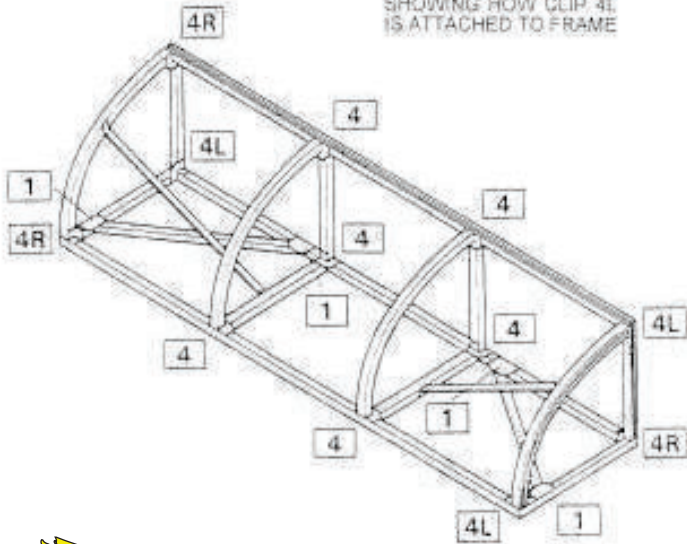

MIDDLE TRUSS

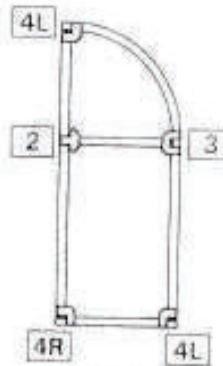

END TRUSS

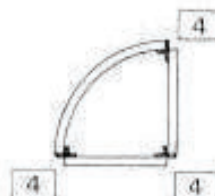

MIDDLE TRUSS

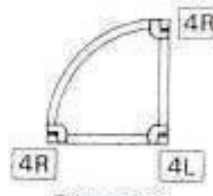

END TRUSS

- 1
- 2
- 3
- 4L
- 4R
- 5L
- 5R
- 6
- 7
- 8
- 9





# INSTALLATION INSTRUCTIONS

Fasten clips to awning structure using tek-screws and screw gun as shown in the illustration that most closely resembles the awning you are fabricating.

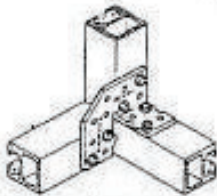
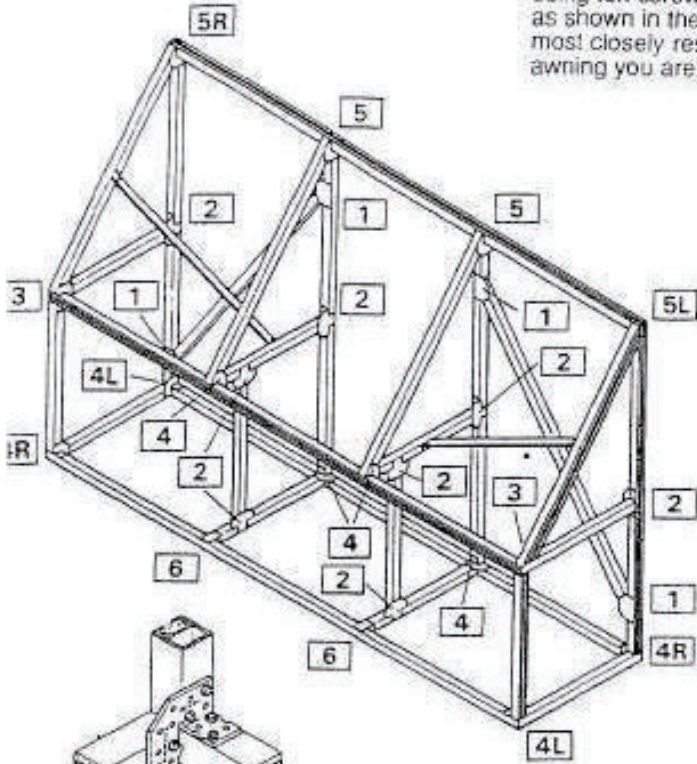

SAMPLE INSTALLATION SHOWING HOW CLIP 4L IS ATTACHED TO FRAME

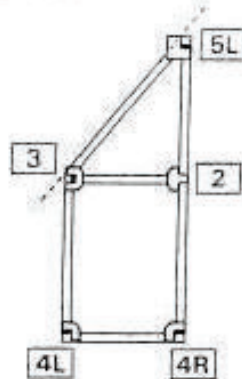
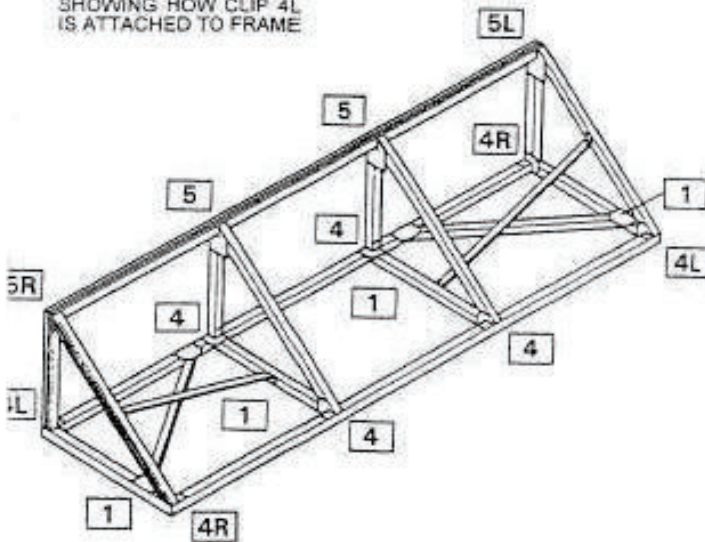



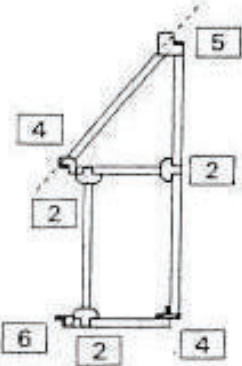



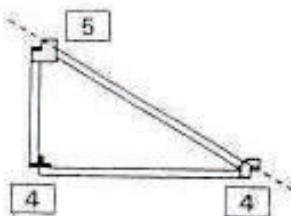



END TRUSS



MIDDLE TRUSS

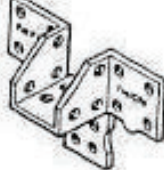

MIDDLE TRUSS

- 1 
- 2 
- 3 
- 4L 
- 4R 
- 5L 
- 5R 
- 6 
- 7 
- 8 
- 9 



# ASSEMBLY PRINTS

## CONVEX

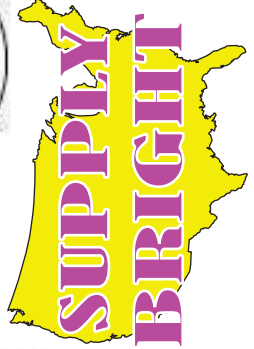
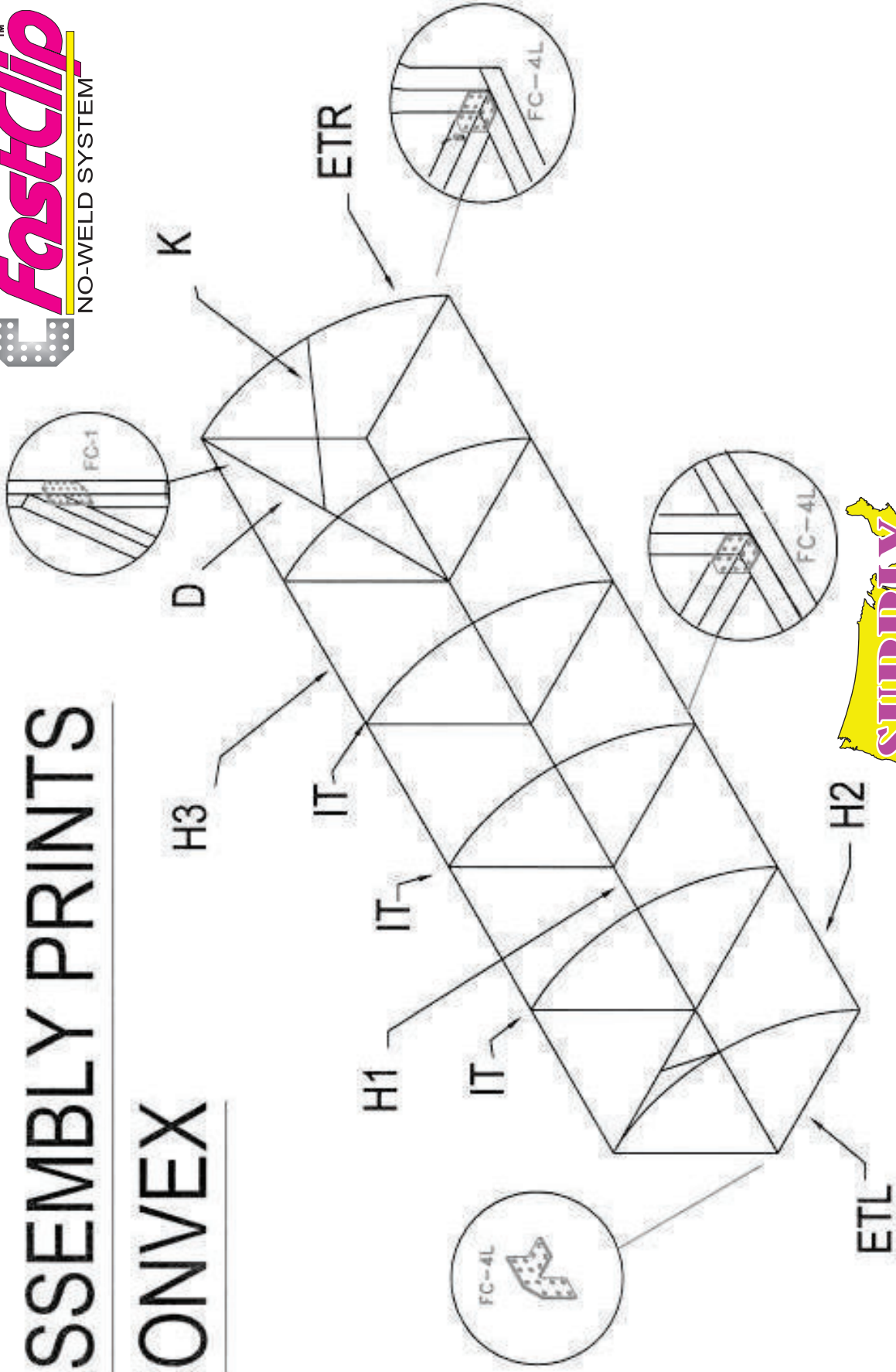



# TRADITIONAL with SIGNBAND

## ASSEMBLY PRINTS

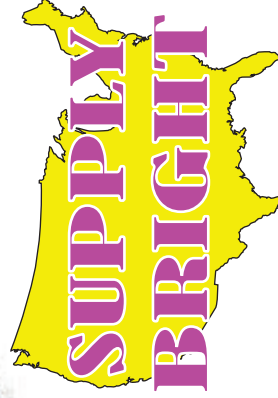
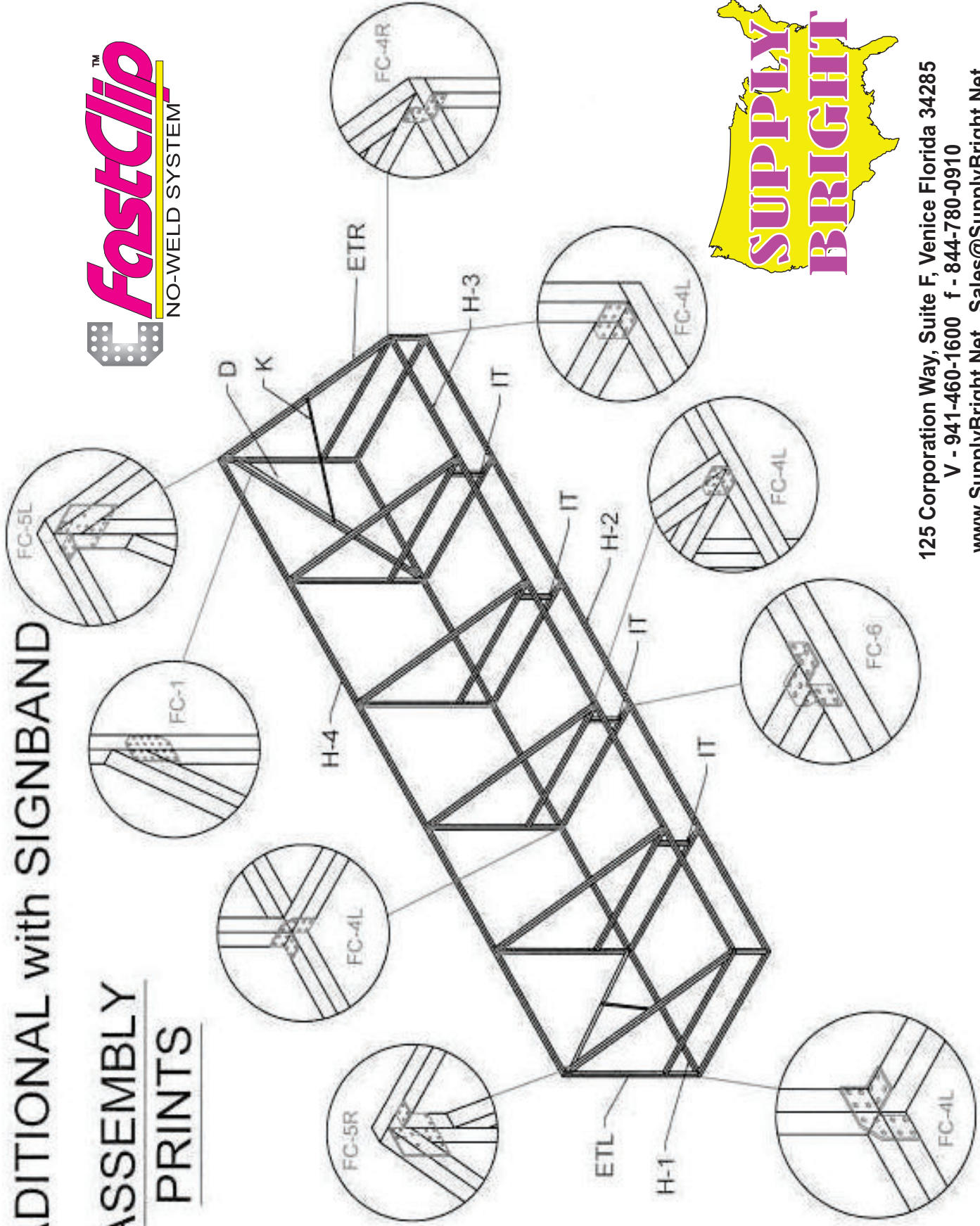

125 Corporation Way, Suite F, Venice Florida 34285  
V - 941-460-1600 f - 844-780-0910  
[www.SupplyBright.Net](http://www.SupplyBright.Net) Sales@SupplyBright.Net

# TYPICAL HIGH HAT CONVEX

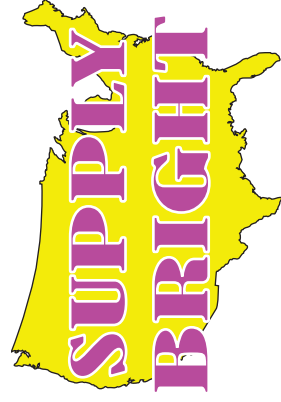
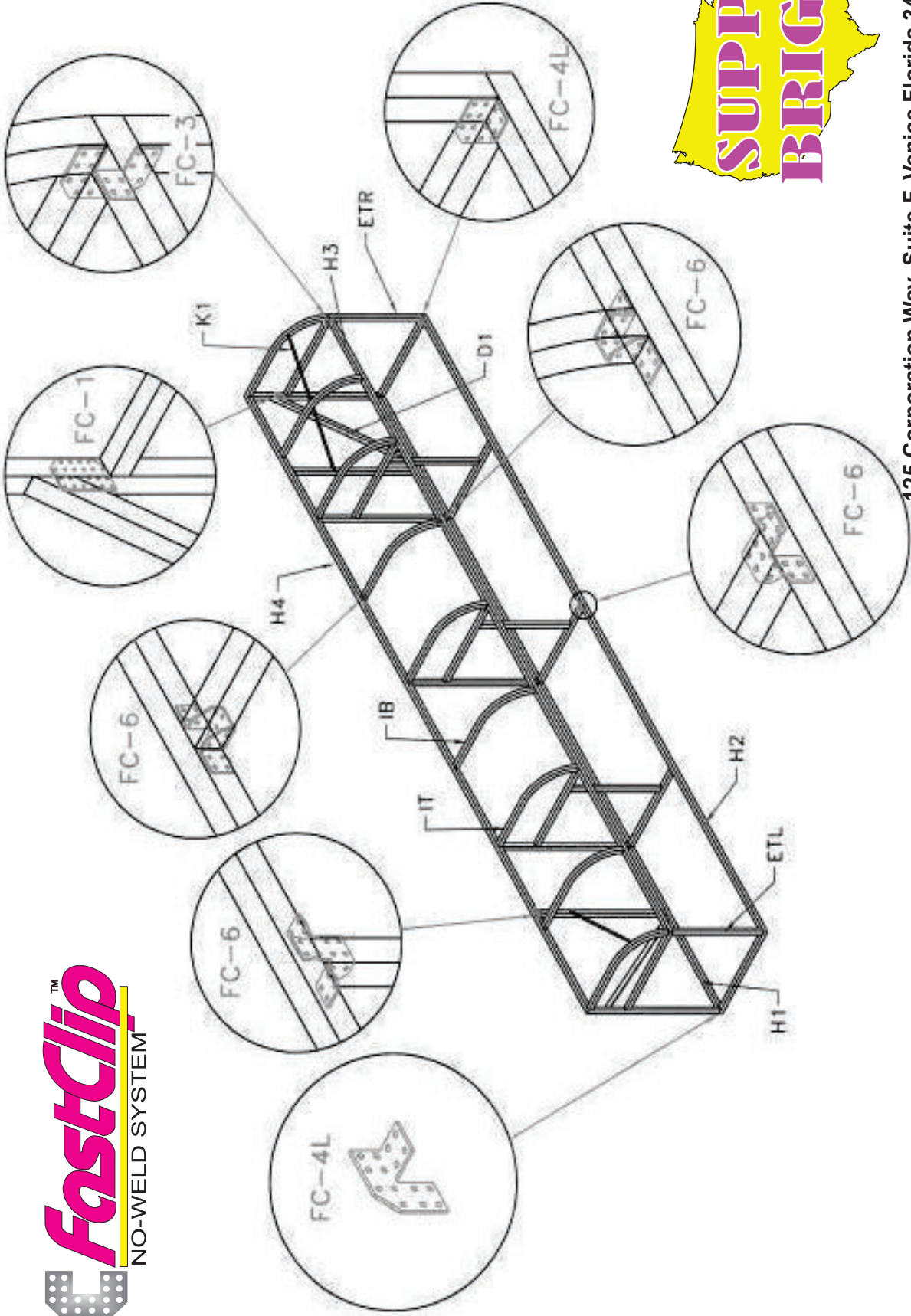

125 Corporation Way, Suite F, Venice Florida 34285  
V - 941-460-1600 f - 844-780-0910  
[www.SupplyBright.Net](http://www.SupplyBright.Net) Sales@SupplyBright.Net



EXPLODED VIEW

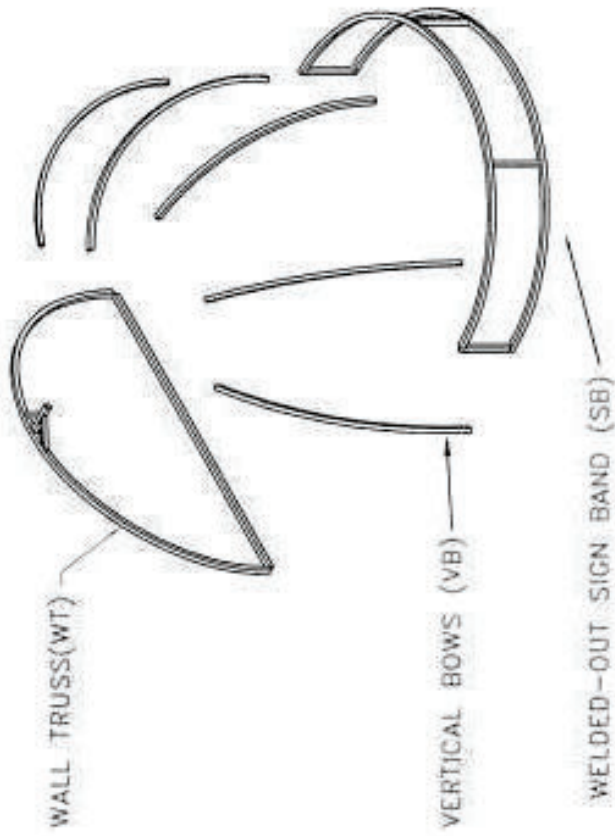

SIDE VIEW

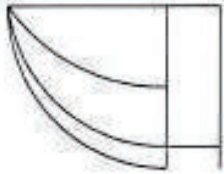

FRONT VIEW

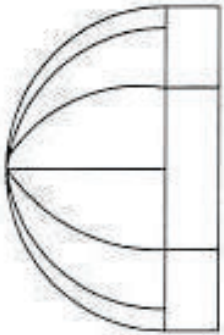

PLAN VIEW

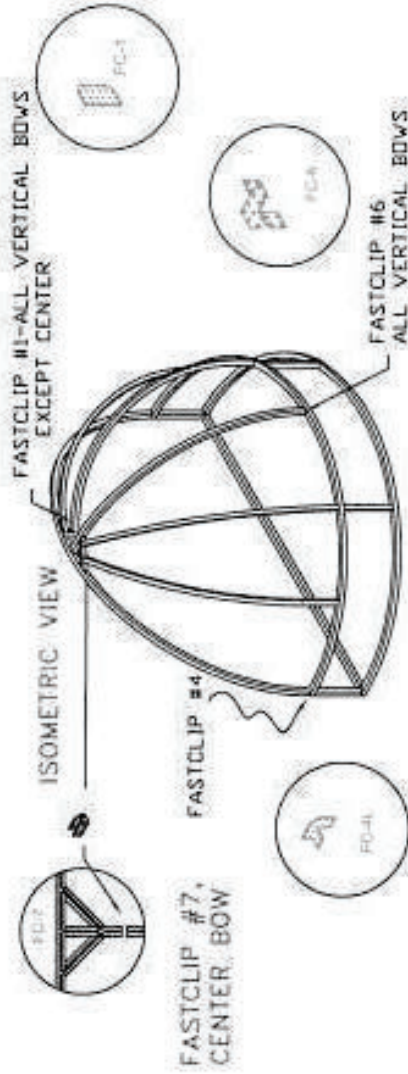
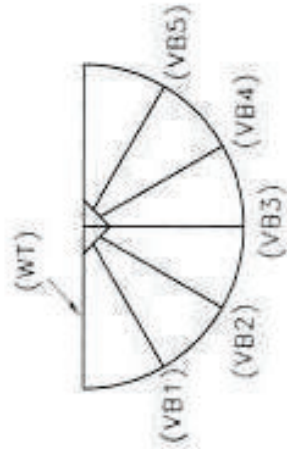
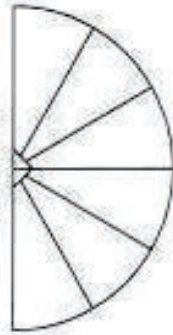

125 Corporation Way, Suite F, Venice Florida 34285  
 V - 941-460-1600 f - 844-780-0910  
 www.SupplyBright.Net Sales@SupplyBright.Net



# ASSEMBLY PRINTS TRADITIONAL

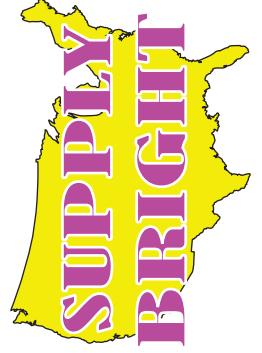
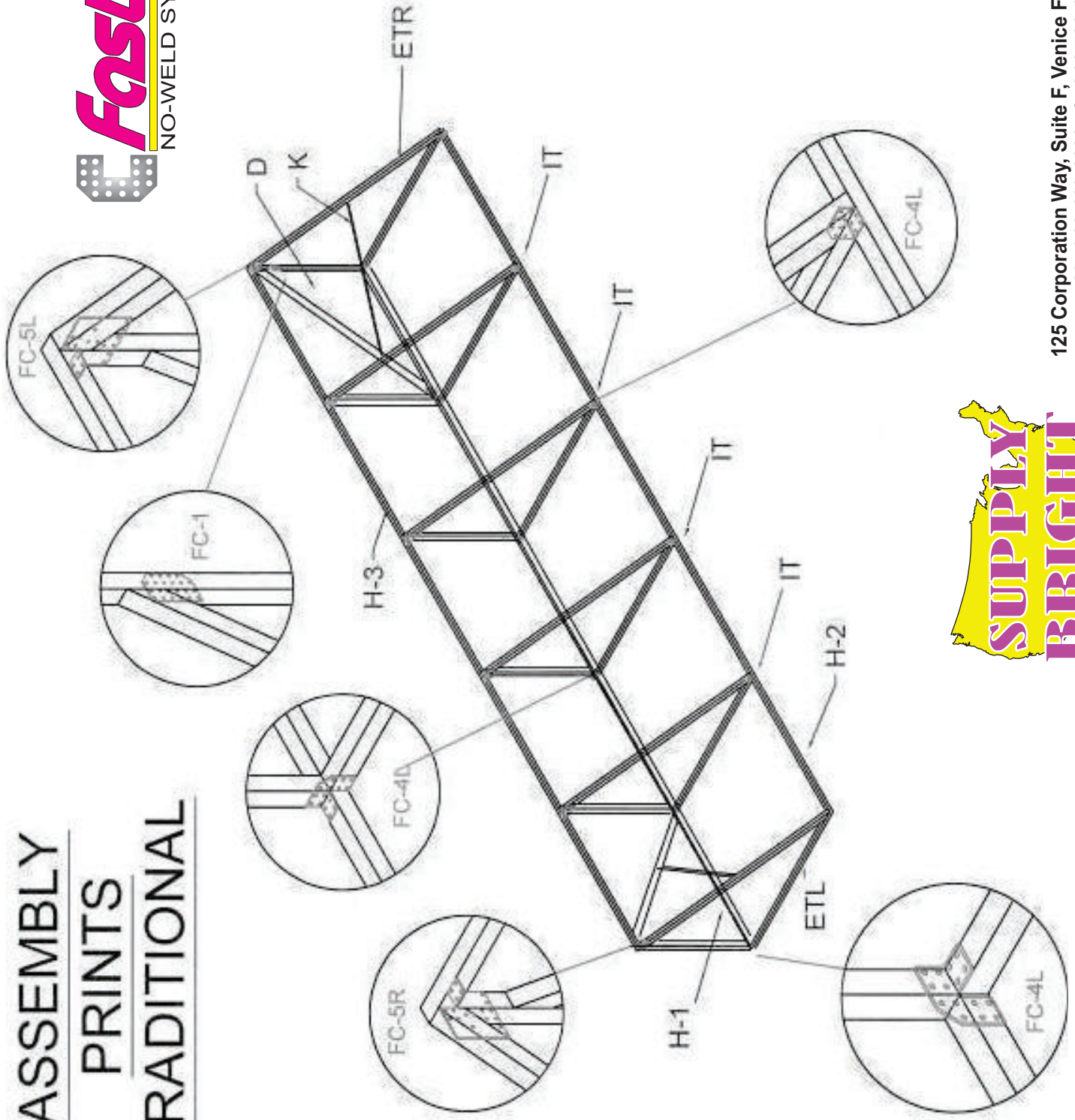

125 Corporation Way, Suite F, Venice Florida 34285  
V - 941-460-1600 f - 844-780-0910  
www.SupplyBright.Net Sales@SupplyBright.Net

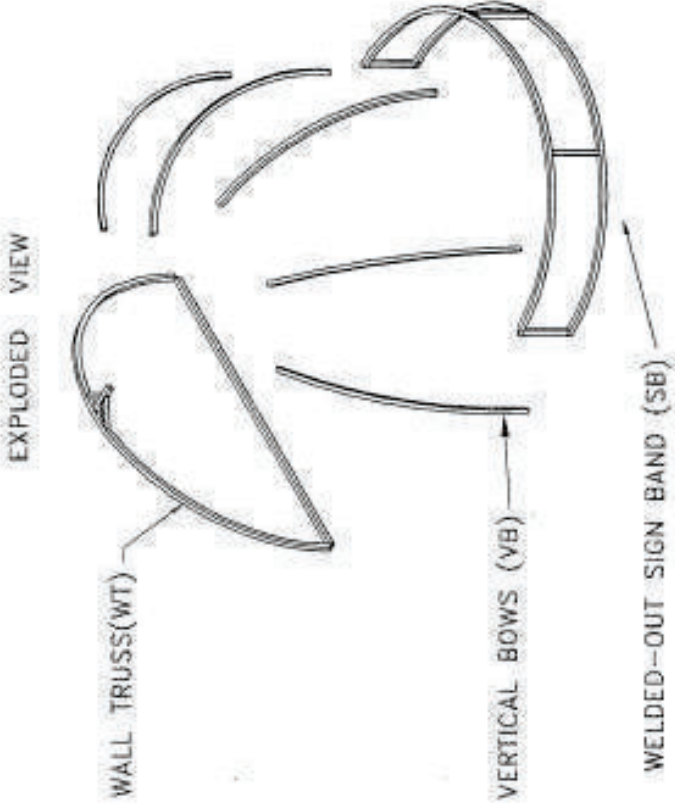
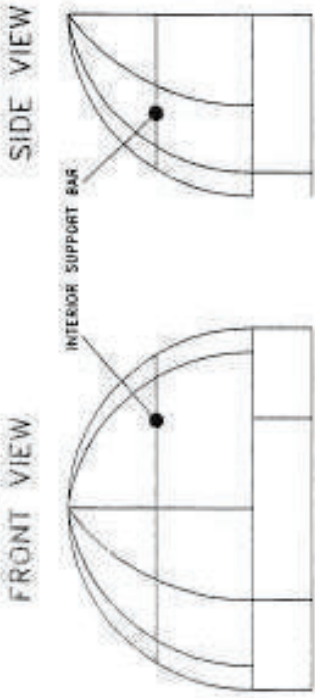

**ASSEMBLY PRINTS**  
 Dome with Sign Band

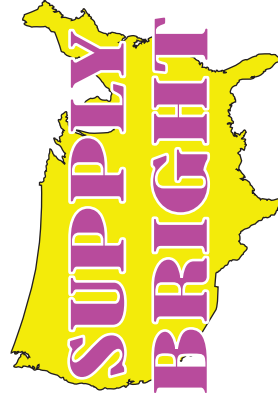
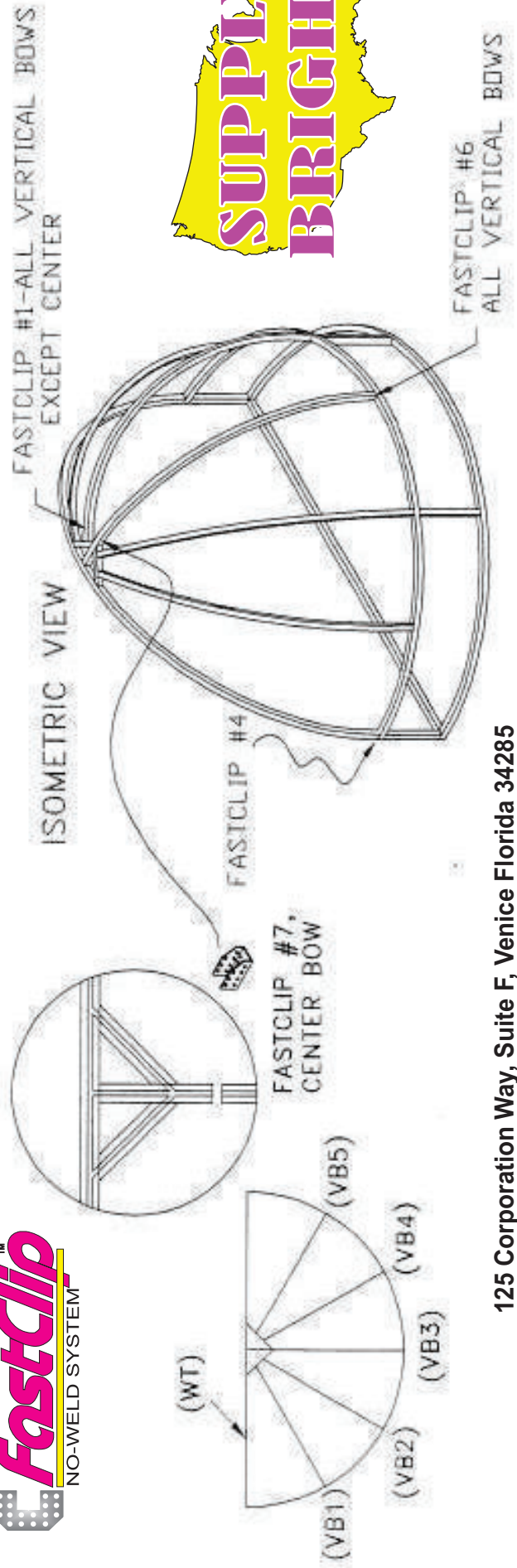

125 Corporation Way, Suite F, Venice Florida 34285  
 V - 941-460-1600 f - 844-780-0910  
 www.SupplyBright.Net Sales@SupplyBright.Net



# TYPICAL RADIUS MARQUEE

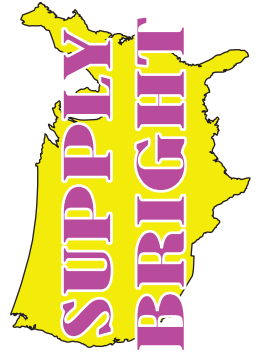
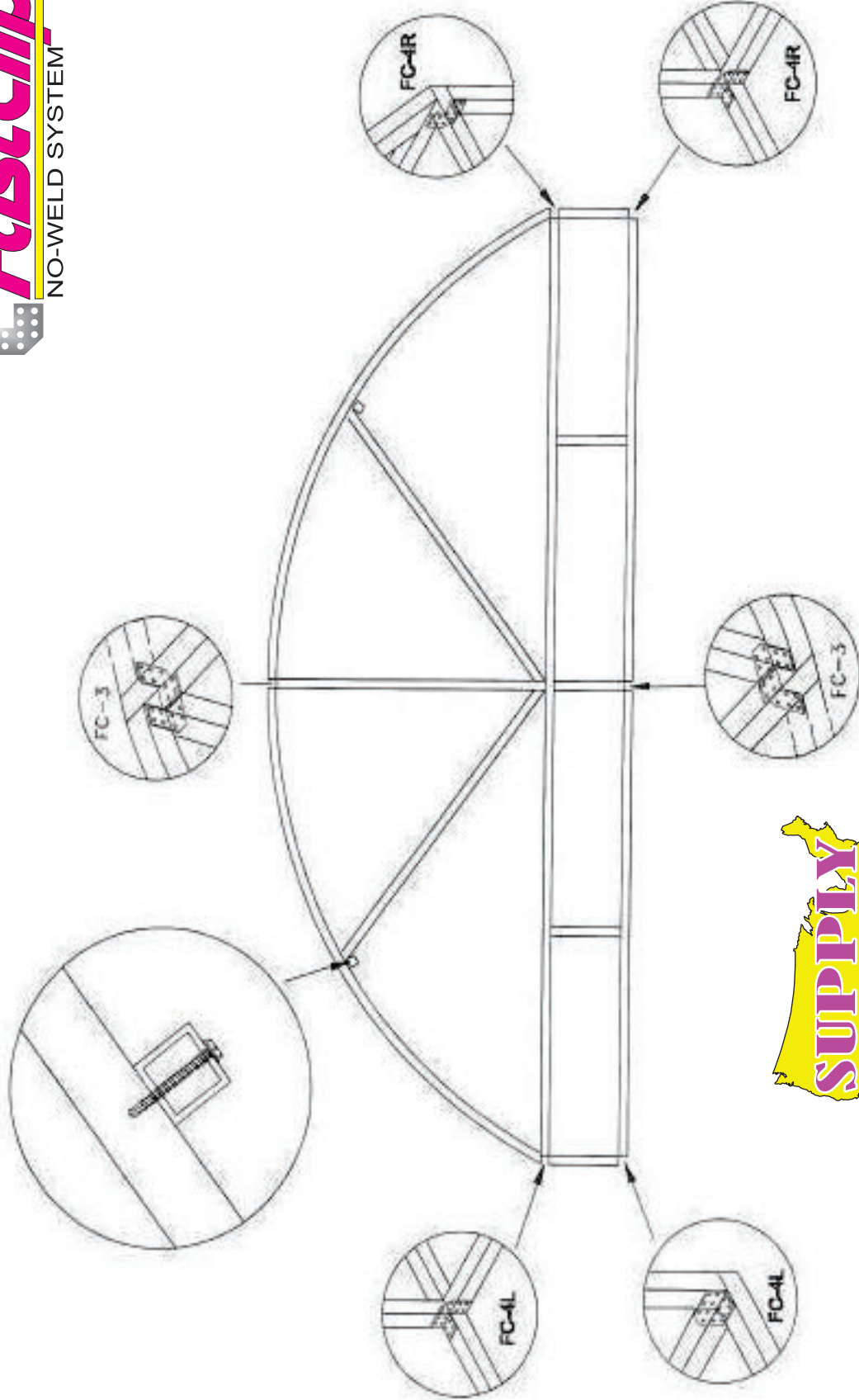

125 Corporation Way, Suite F, Venice Florida 34285  
V - 941-460-1600 f - 844-780-0910  
[www.SupplyBright.Net](http://www.SupplyBright.Net) Sales@SupplyBright.Net

# MARQUEE W/ SIGN BAND HORIZONTAL LAYOUT

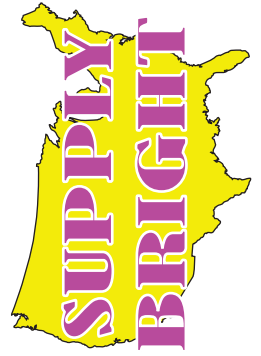
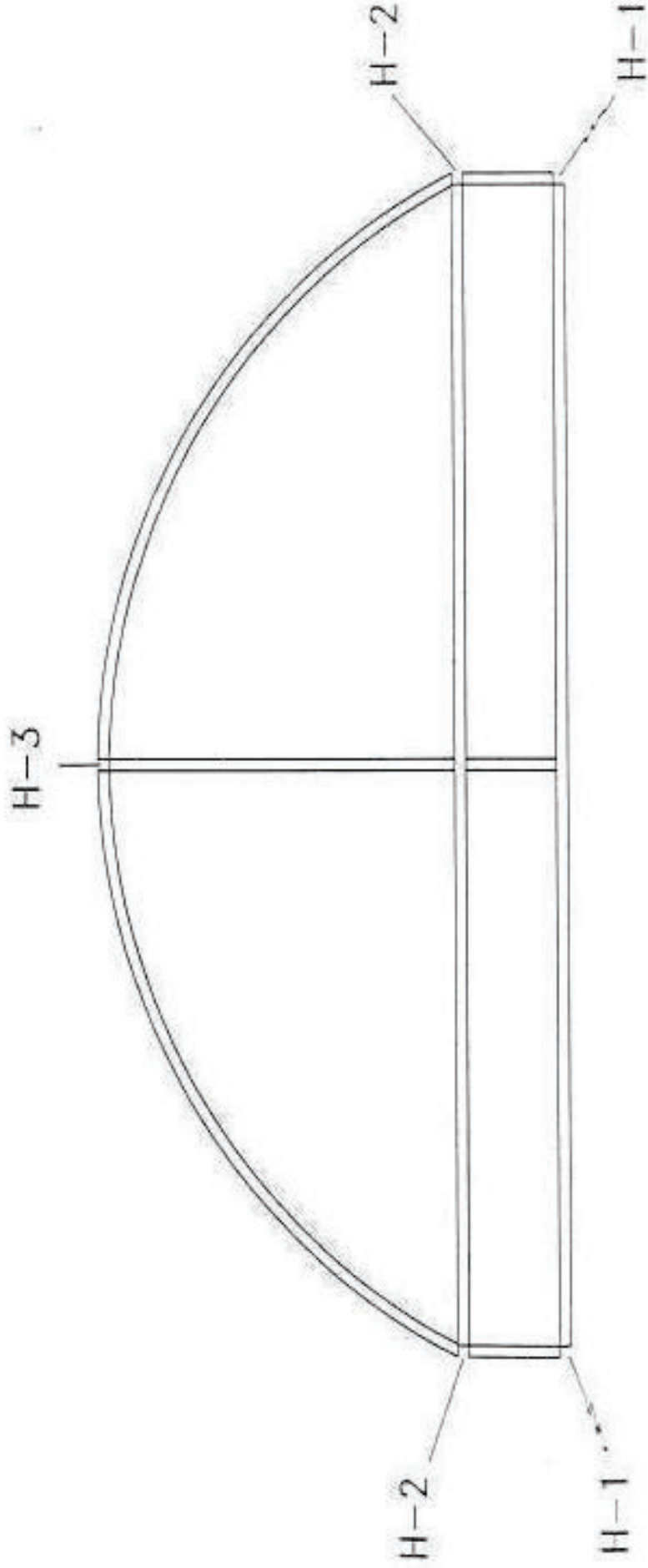

125 Corporation Way, Suite F, Venice Florida 34285  
V - 941-460-1600 f - 844-780-0910  
[www.SupplyBright.Net](http://www.SupplyBright.Net) Sales@SupplyBright.Net



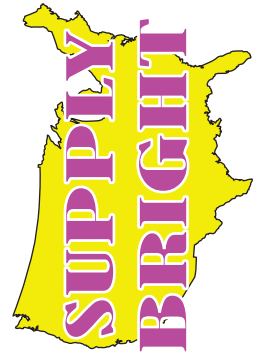
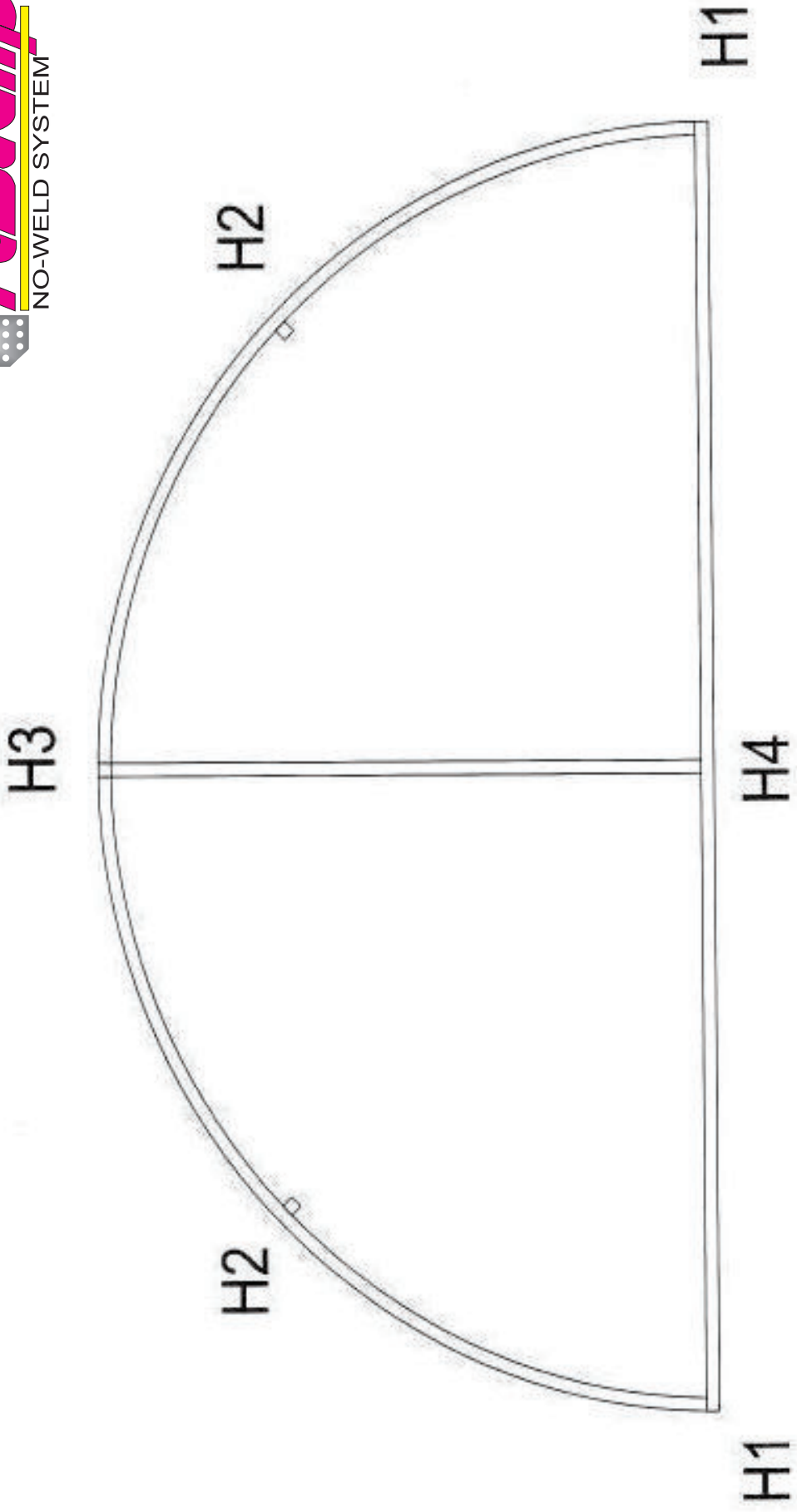

125 Corporation Way, Suite F, Venice Florida 34285  
V - 941-460-1600 f - 844-780-0910  
www.SupplyBright.Net Sales@SupplyBright.Net

# MARQUEE W/ SIGN BAND

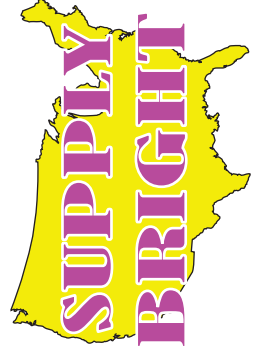
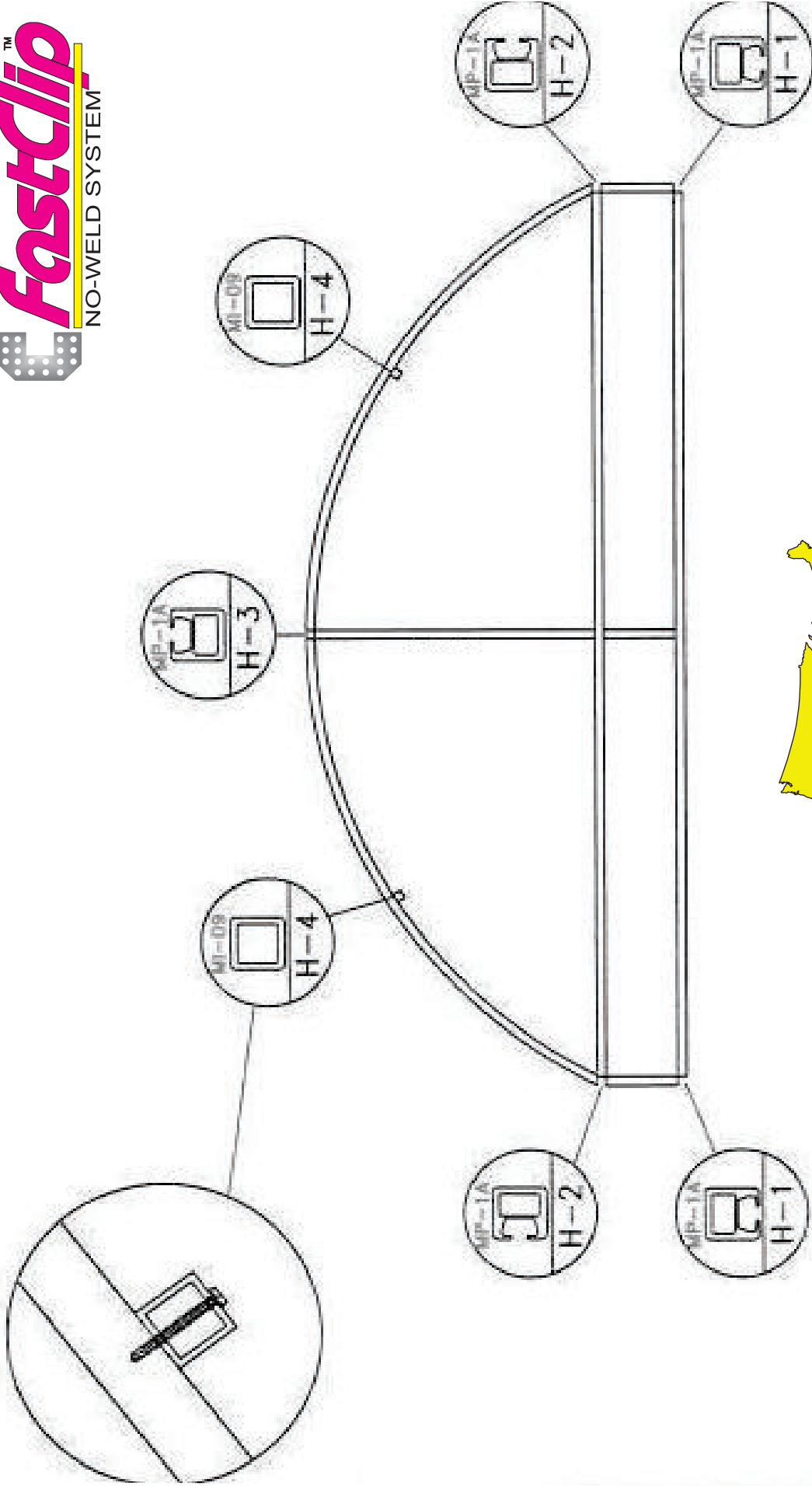

125 Corporation Way, Suite F, Venice Florida 34285  
V - 941-460-1600 f - 844-780-0910  
[www.SupplyBright.Net](http://www.SupplyBright.Net) Sales@SupplyBright.Net



# MARQUEE W/ SIGN BAND

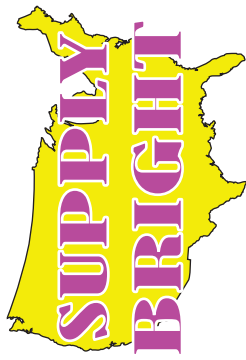
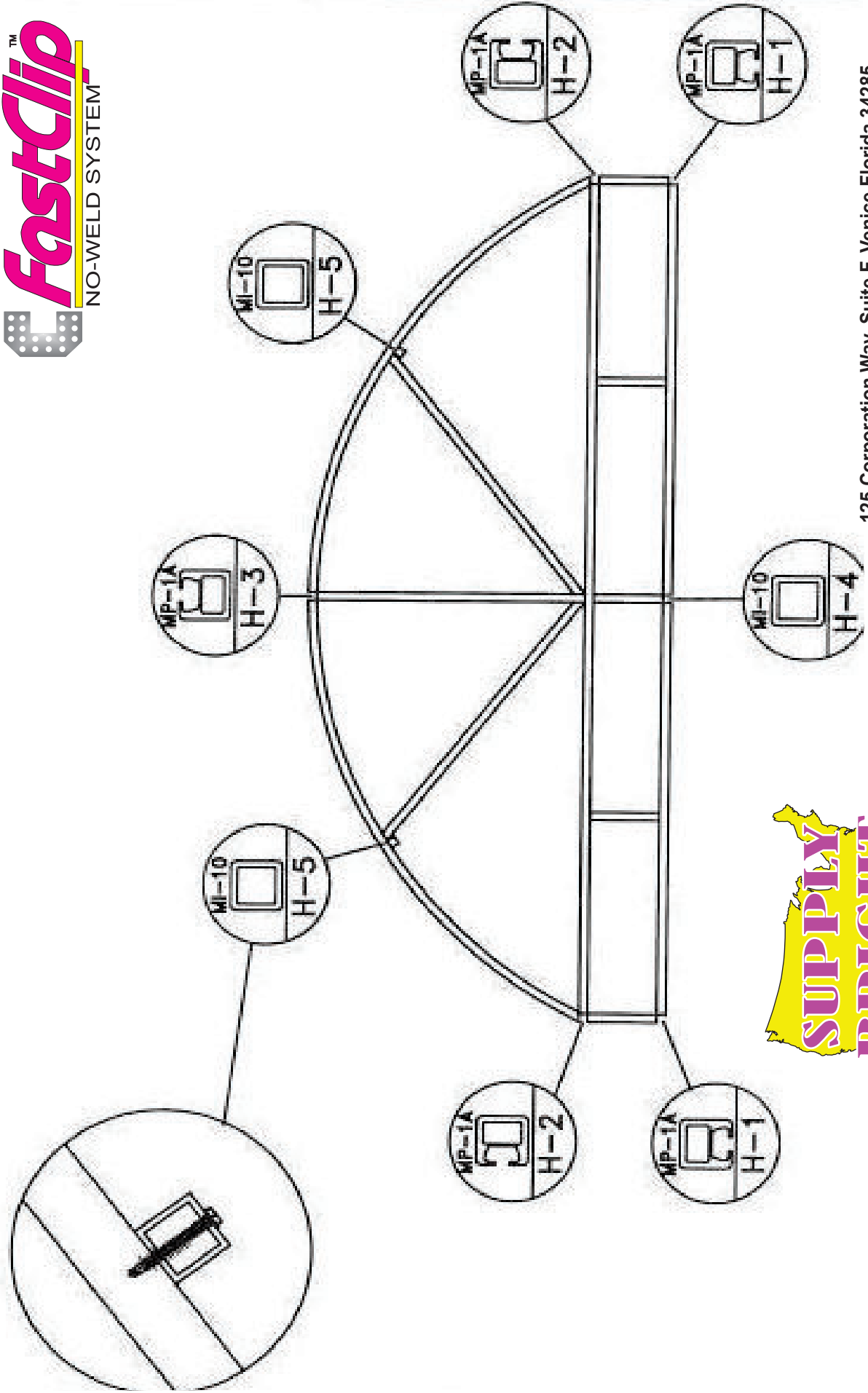

125 Corporation Way, Suite F, Venice Florida 34285  
V - 941-460-1600 f - 844-780-0910  
www.SupplyBright.Net Sales@SupplyBright.Net

# TYPICAL GABLE MARQUEE

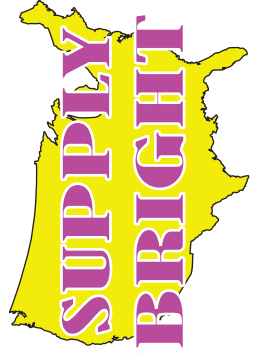
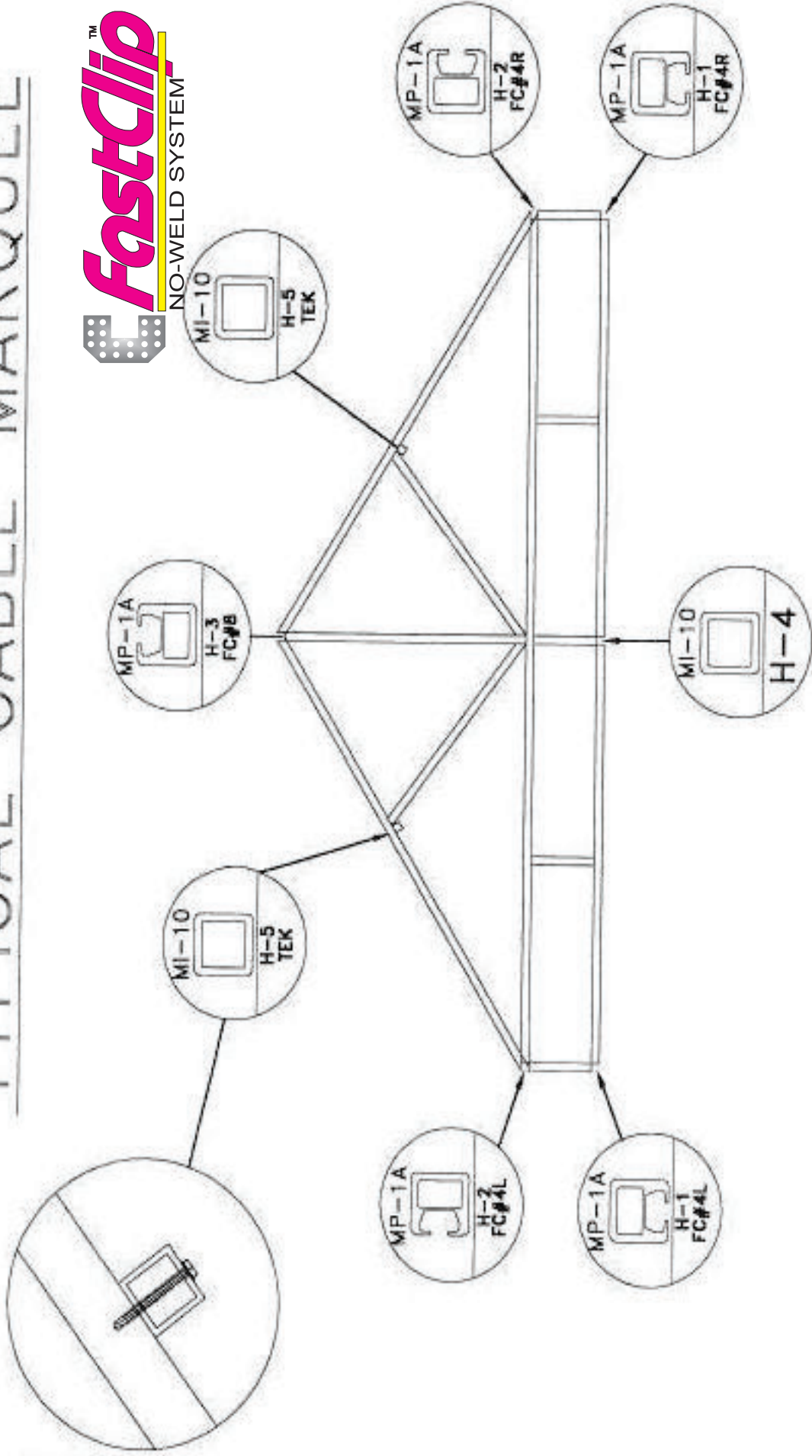

125 Corporation Way, Suite F, Venice Florida 34285  
V - 941-460-1600 f - 844-780-0910  
[www.SupplyBright.Net](http://www.SupplyBright.Net) Sales@SupplyBright.Net

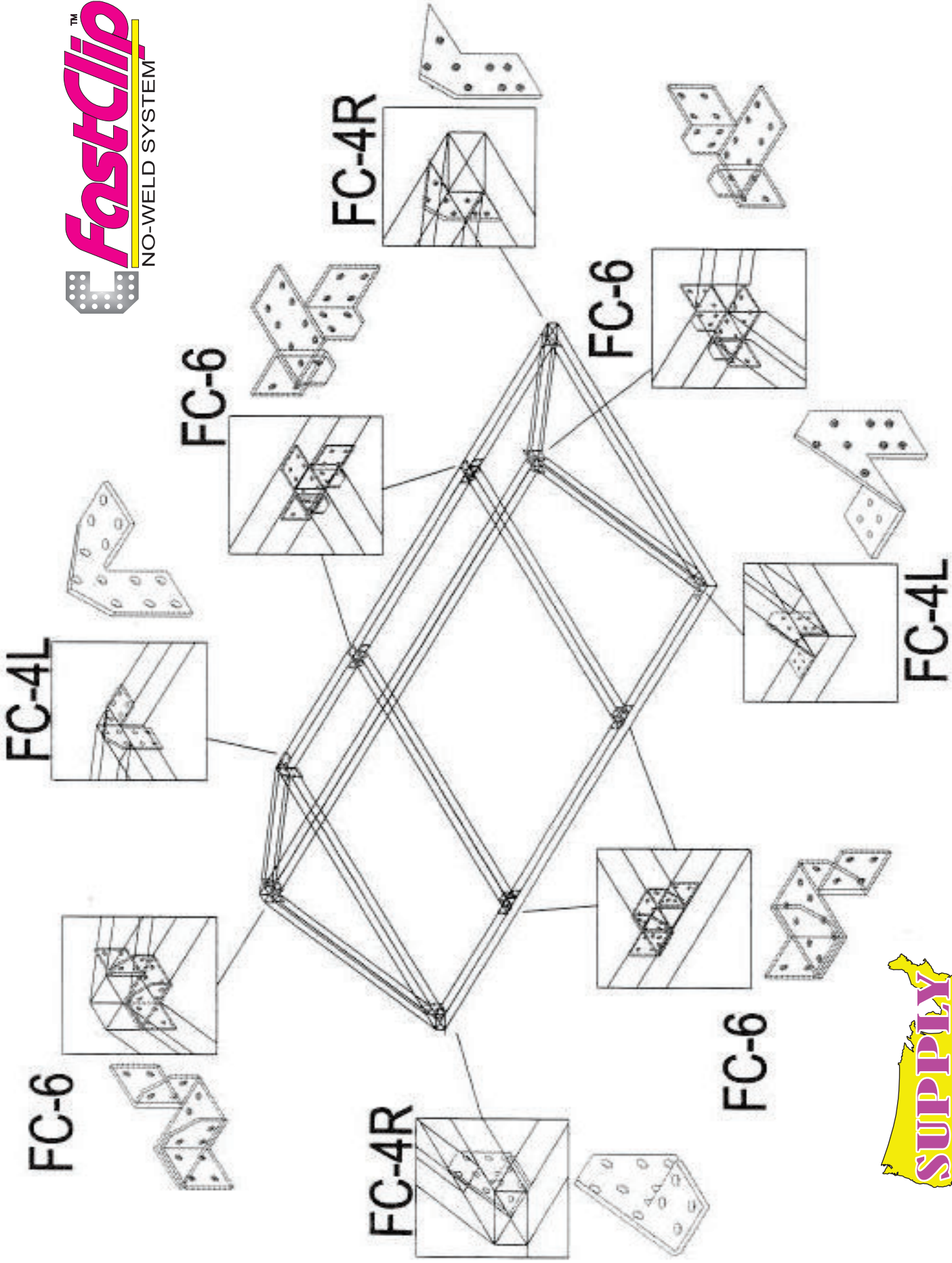

125 Corporation Way, Suite F, Venice Florida 34285  
 V - 941-460-1600 f - 844-780-0910  
 www.SupplyBright.Net Sales@SupplyBright.Net

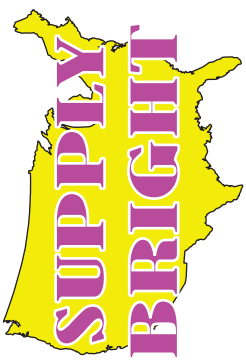





# Z-CLIP

*Standard Awning Designs Showcasing  
Z-Clip Technical Information*

125 Corporation Way, Suite F, Venice Florida 34285  
V - 941-460-1600 f - 844-780-0910  
[www.SupplyBright.Net](http://www.SupplyBright.Net) [Sales@SupplyBright.Net](mailto:Sales@SupplyBright.Net)

# Z-CLIP

## "Z" CLIP DETAIL

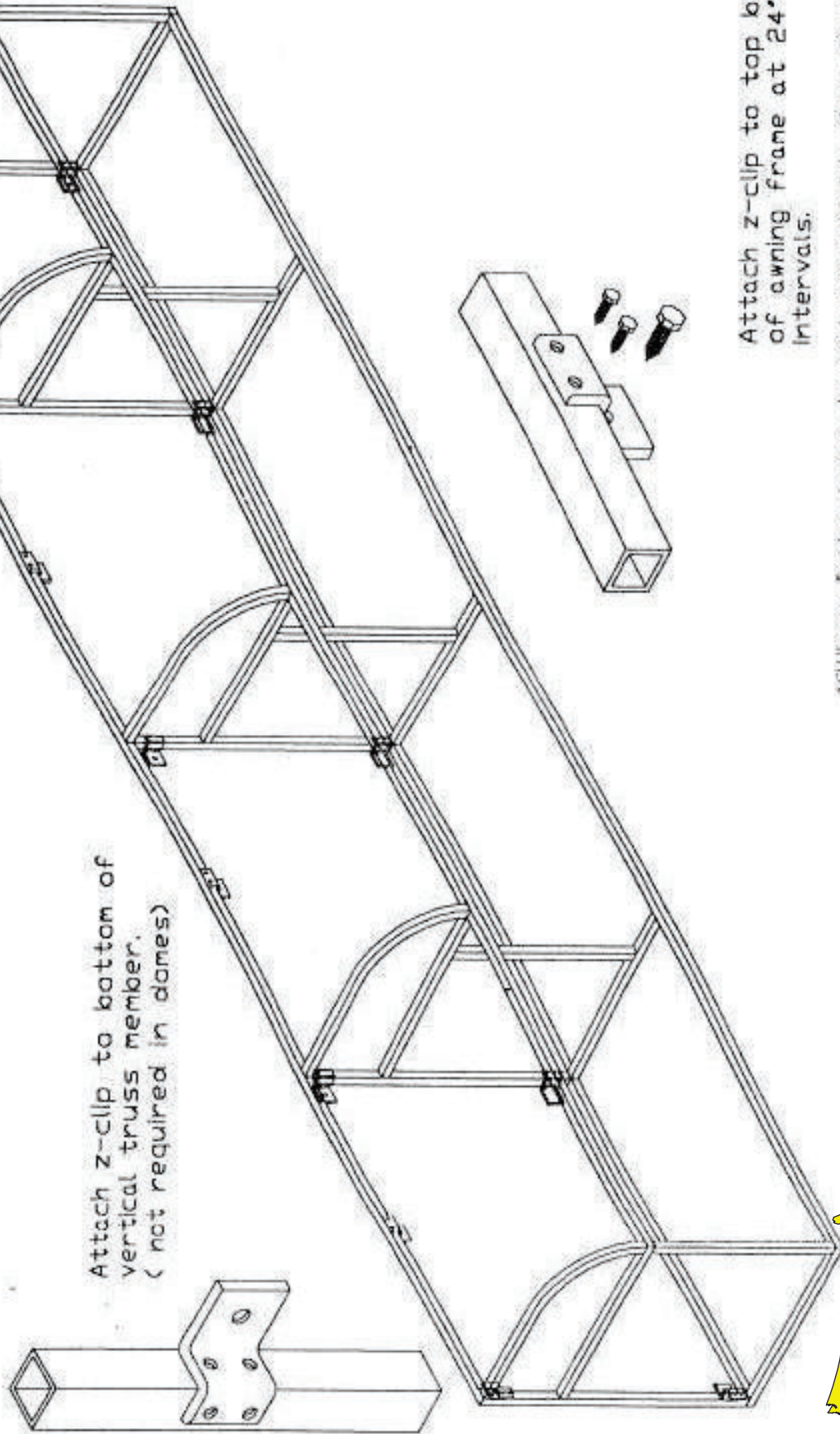

Attach z-clip to bottom of vertical truss member. (not required in domes)

Attach z-clip to top bar of awning frame at 24' +/- intervals.

Miliken Industries is not responsible for final attachment or fasteners and are shown here for illustration purposes only.

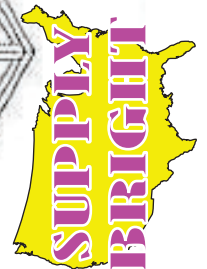

125 Corporation Way, Suite F, Venice Florida 34285  
V - 941-460-1600 f - 844-780-0910  
[www.SupplyBright.Net](http://www.SupplyBright.Net) Sales@SupplyBright.Net

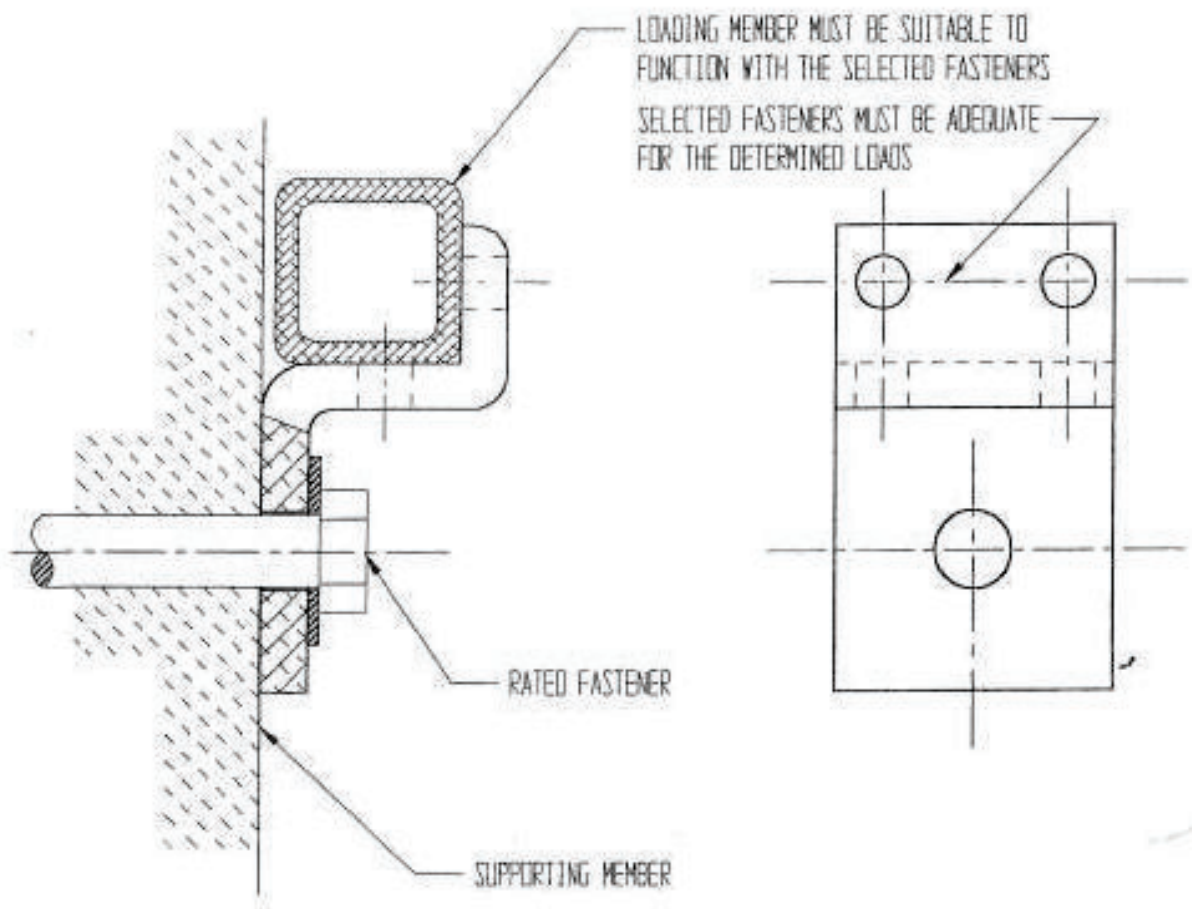

Z-CLIP ASSEMBLY



*David J. Haley*  
6-1-99



125 Corporation Way, Suite F, Venice Florida 34285  
V - 941-460-1600 f - 844-780-0910  
www.SupplyBright.Net Sales@SupplyBright.Net

SCALE: 1" = 1"  
DATE: 06-01-99

FILE NO: 167007A.PRT

David J. Haley, PE  
Professional Engineering  
8 Dudley Circle  
Durham, NC 27703

MILLIKEN INDUSTRIES  
Z-CLIP





**David J. Haley, PE**

8 Dudley Circle • Durham, NC 27703 • (919) 596-8411, FAX 598-9664

### Z-Clip Vertical and Horizontal Allowable Loads

**Schedule for Variable Loads**

V (lbs)	Pv (psi)	H (lbs)	Ph (psi)
1500	1143	0	0
1400	1067	24	21
1300	990	47	42
1200	914	71	63
1100	838	94	84
1000	762	118	105
900	686	141	125
800	610	165	146
700	533	188	167
600	457	212	188
500	381	235	209
400	305	259	230
300	229	282	251
200	152	306	272
100	76	329	293
0	0	353	314

Fastener maximum tension load is specified as  $F = 1000$  lbs

V maximum of 1500 lb is determined by analysis of the crushing and shear forces of the Z-Clip

V = Vertical force

Pv = Vertical pressure

H = Horizontal force

Ph = Horizontal pressure

Values may be positive or negative

Values for V and H are calculated by the formula  $750 \Rightarrow 0.5V + 2.125H$

**Design Comments:**

This certification is for worst case loading of the Z-Clip using the Schedule for Variable Loads.

This certification is for the Z-Clip only as identified by Drawing No. 167007.PRT and installed as shown in Drawing No. 167007A.PRT by David J. Haley, PE.

The extreme values of V and H in the Schedule for Variable Loads are not very practical since it is unlikely that a condition would exist where there would be no horizontal or vertical loads. The appropriate loads on the Z-Clip must be determined by the designer of the loading structure.

It is assumed and integral to this analysis that the Z-Clip is fastened to a solid structure that is suitable to resist the imposed loads.

A 3/8" diameter fastener is anticipated which is generally commercially available to provide four times the design load maximums of 1,000 lb pull out and 1,500 lb shear. Smaller fasteners may be selected by the designer if appropriate to the loads.

The manufacturer's pull-out and shear values for the selected fastener must be 4 times greater than the load determined to be acting on the fastener.



125 Corporation Way, Suite F, Venice Florida 34285  
V - 941-460-1600 f - 844-780-0910  
www.SupplyBright.Net Sales@SupplyBright.Net

